

ONETENDERS

C-SERIES

Catamaran

STABLE | SPACIOUS | UNSTOPPABLE



The C42 is a 4.2m catamaran tender built using pre-preg carbon construction for exceptional strength and lightweight. Its twin-hull design ensures unmatched stability, dryness and comfort, even at speed, while the side console layout adds control, space and ease of use. Purpose-built and performance proven, the C42 combines cutting-edge composite technology with sleek performance on the water.

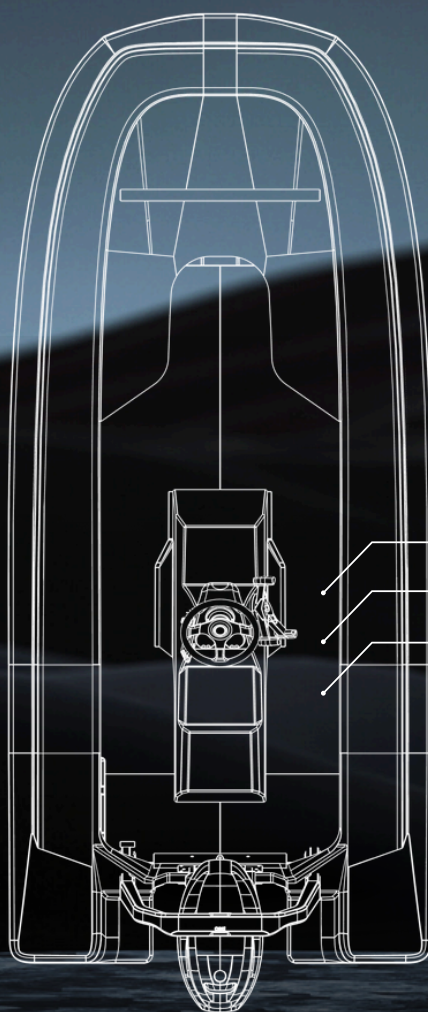

C42

| | |
|------------------|--------|
| WEIGHT (CARBON): | 120KGS |
| LOA: | 4.2M |
| BEAM: | 1.95M |
| PAX: | 5-6 |
| REC HP: | 40 |

- LARGE INTERNAL VOLUME
- ELECTRIC COMPATIBLE
- STABLE & DRY

100 KGS
1.95M
500 KGS
4-5 PAX

STANDARD FEATURES

- MARINE FOAM DECKING
- WRAP AROUND FENDER
- 6 X CARBON FIBER HANDLES
- 4 X INTERNAL LIFTING POINTS
- TRANSOM LIFTING/ TOWING POINT
- BOW HANDLE/ TOWING POINT
- KEEL PROTECTIVE STRIPS
- CARBON FIBER BOW PROTECTORS

OPTIONS

- | | |
|-----------------|---------------------------|
| CROSSMEMBER | CARBON ARCH |
| CARBON OARS | CUSTOM PAINT WORK |
| BOARDING LADDER | CUSTOMISED LIFTING POINTS |
| BOW SEAT | BOW PLATFORM |
| EXTRA HANDLES | STORAGE MESH BAGS |
- BENCH SEAT/ CONSOLE OPTIONS AVAILABLE BY REQUEST



C42 DIMENSIONS

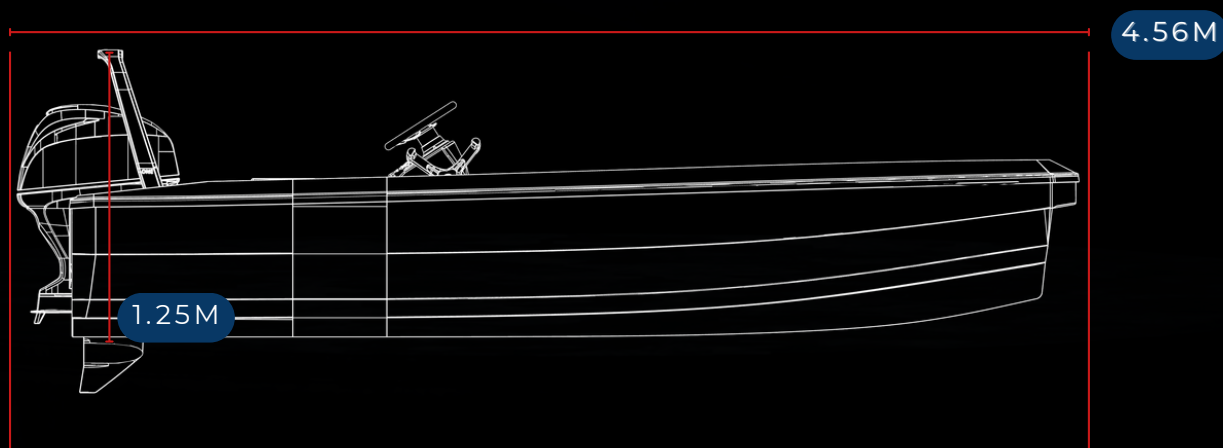
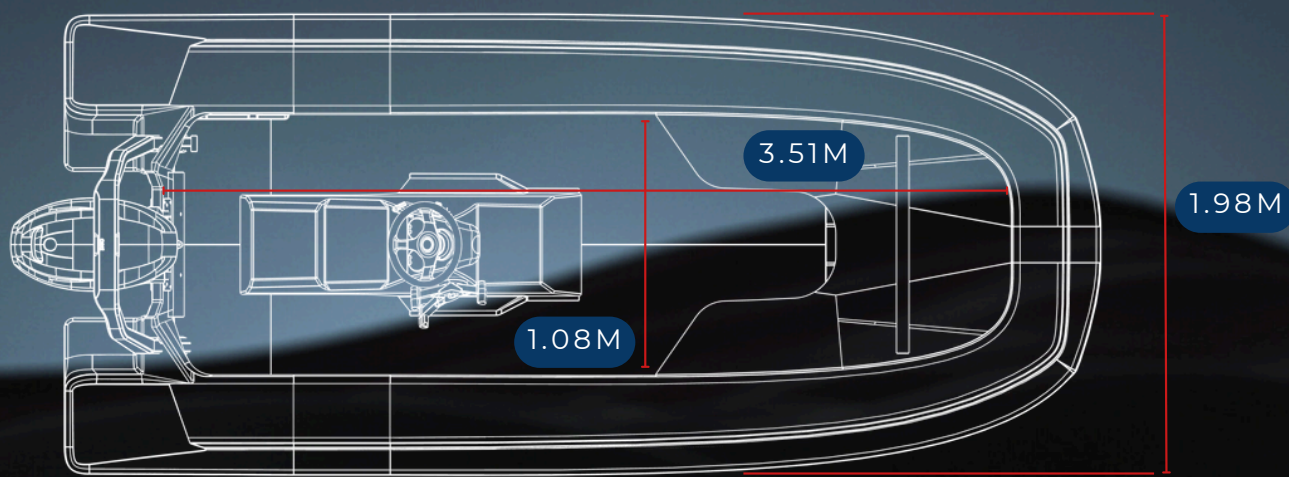

THE *Ultimate* CARBON FIBER TENDER

